

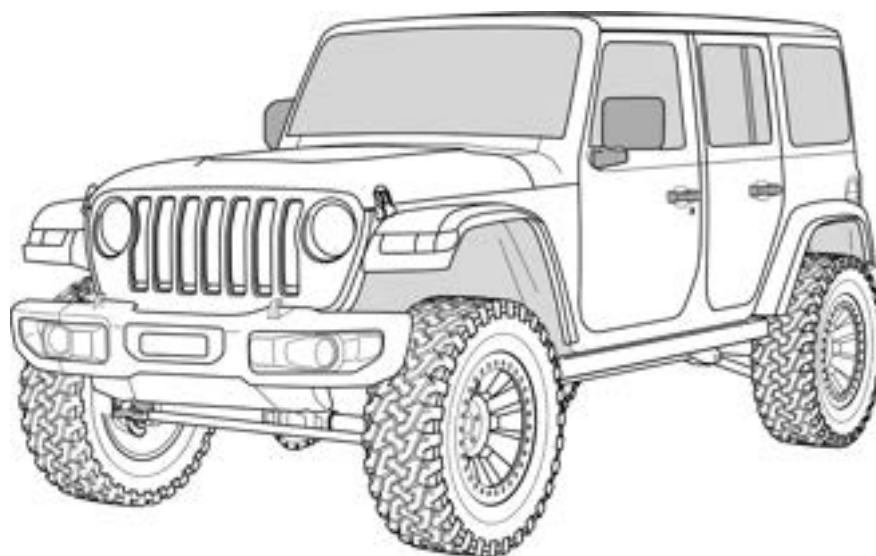

Jeep JL 2.5" Spring Lift

www.TERAFLEX.com



Important Notes:

Prior to beginning this install, or any installation, read the instructions thoroughly to familiarize yourself with the required steps. Evaluate if you are experienced and capable to personally perform these modifications. A factory service manual should be used in conjunction with these installation instructions.

This product will change the highway handling characteristics of your vehicle, exercise caution. After altering the suspension it is always advisable to have an alignment done by a competent 4 wheel drive shop or by an alignment shop that is experienced with lifted 4 wheel drive vehicles.

Refer to the parts list to ensure that all necessary components and hardware has been included. If any parts are missing please contact your local TeraFlex dealer for assistance.

NOTE: Some form of caster correction is required for the base spring lift kit

If a 37" tire is being installed on a Sport or Sahara additional up travel limit may be required using Bumpstop Spacer Kit #1959300.

Due to differences from Jeep to Jeep, there may be a need to purchase the Rear Track Bar Bracket to help prevent contact between the drive shaft and gas tank.



Rear Track Bar Bracket Part # 1953600



Tools Needed:



- Metric Sockets and Open End Wrenches
- Torque Wrench
- Factory Service Manual
- General Mechanics Tools

Maintenance Note:



After the first 300 miles and every 3,000 miles after that, re-torque all the suspension components and bolts.





3.6L V6 & 2.0L I4 - 4-Door			Base 2.5" Lift	ST2/CT2	RT2
Image	Part #	Name	Qty	Qty	Qty
	02-21-201-250-1	Spring (T), Jeep JL / Front, Dual Rate / Sport, 4Dr 2.50" / 2Dr 3.50" Lift, Cascade Black	2	2	2
	02-22-211-250-1	Spring (T), Jeep JL / Rear, Left / Sport, 4Dr 2.50" / 2Dr 3.50" Lift, Cascade Black	1	1	1
	02-22-221-250-1	Spring (T), Jeep JL / Rear, Right / Sport, 4Dr 2.50" / 2Dr 3.50" Lift, Cascade Black	1	1	1





3.6L V6 & 2.0L I4 - 2-Door			Base 2.5" Lift	ST2/CT2	RT2
Image	Part #	Name	Qty	Qty	Qty
	02-21-201-200-1	Spring (T), Jeep JL / Front, 2 Door / Dual Rate / Sport, 2.50" Lift, Cascade Black	2	2	2
	02-22-211-200-1	Spring (T), Jeep JL / Rear, Left / Sport, 2Dr 2.50" Lift, Cascade Black	1	1	1
	02-22-221-200-1	Spring (T), Jeep JL / Rear, Right / Sport, 2Dr 2.50" Lift, Cascade Black	1	1	1

4xe - 4-Door			Base 2.5" Lift	ST2/CT2	RT2
Image	Part #	Name	Qty	Qty	Qty
	02-21-401-001-1	Spring (T), Jeep JL/JT / Front, 4-Door / Dual Rate / Sport, 2.5" Lift, Black	2	2	2
	02-22-431-350-1	Spring (T), Jeep JL / Rear, 4-Door / Single Rate / HD 3.50" Lift, Black	2	2	2

Diesel - 4-Door			Base 2.5" Lift	ST2/CT2	RT2
Image	Part #	Name	Qty	Qty	Qty
	02-21-401-001-1	Spring (T), Jeep JL/JT / Front, 4-Door / Dual Rate / Sport, 2.5" Lift, Black	2	2	2
	02-22-411-250-1	Spring (T), Jeep JL / Rear, 4-Door / Left / Sport, 3.50" Lift, Cascade Black	1	1	1
	02-22-421-250-1	Spring (T), Jeep JL / Rear, 4-Door / Right / Sport, 3.50" Lift, Cascade Black	1	1	1

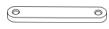
392 - 4-Door			Base 2.5" Lift	ST2/CT2	RT2
Image	Part #	Name	Qty	Qty	Qty
	02-21-631-350-1	Spring (T), Jeep JT / Front, 4-Door / Dual Rate / HD 3.50" Lift, Black	2	2	2
	02-22-411-400-1	Spring (T), Jeep JL / Rear, 4-Door / Left / Sport, 3.50" Lift, Cascade Black	1	1	1
	02-22-421-400-1	Spring (T), Jeep JL / Rear, 4-Door / Right / Sport, 3.50" Lift, Cascade Black	1	1	1

All Trims - 2-Door & 4-Door			Base 2.5" Lift	ST2/CT2	RT2
Image	Part #	Name	Qty	Qty	Qty
	05-03-001-001	Spring Mount (S), Coil Isolator, Jeep JL Wrangler, Front / Lower	2	2	2
	1101255	Universal, Accessory, Front Brake Line Anchor, Part, 5" Long/.50" Bolt Hole, Boxed	-	-	1
	12-01-109-200	Bumpstop (T), Bottom Spacer, Front / 18-Current Jeep JL Wrangler, 2.00" Lift Height	2	2	-
	12-01-209-200	Bumpstop (T), Top Spacer, Rear / 18-Current Jeep JL Wrangler, 2.00" Lift Height	2	2	**

	12-02-109-050	Bumpstop (T), Spacer, Front / 18-Current Jeep JL Wrangler, 0.50" Lift Height	4	4	-
	12-02-209-001	Bumpstop (S), Bracket, Rear / 18-Current Jeep JL Wrangler, Mounting Strap / M10 X 1.5	2	2	**
	12-02-209-002	Bumpstop (S), Bracket, Rear / 18-Current Jeep JL Wrangler, Mounting Plate	2	2	**
	12-02-209-050	Bumpstop (T), Spacer, Rear / 18-Current Jeep JL Wrangler, 0.50" Lift Height	4	4	**
	21-01-001-115	Sway Bar (S), Link, Swivel Stud, 11.5" Length C-C	2	2	2
See Below	5087*	Hardware Pack, 2.0" Rear Bumpstop Spacer, Jeep JL Wrangler	1	1	-
See Below	5088*	Hardware Pack, 2" Front Bumpstop, Jeep JL Wrangler	1	1	-
See Below	5095*	Hardware Pack JL Rear Swaybar Link	1	1	1
	744500	Sway Bar (S), Link, Swivel Stud, 10.75" Length C-C	2	-	-

*Hardware Packs - 2-Door & 4-Door			Base 2.5" Lift	ST2/CT2	RT2
5087 - Hardware Pack - 2.0" Rear Bumpstop Spacer					
	23-07-03-001	Mounting Hardware (S), Nut, Fuji / Flanged, M10 x 1.5 / Yellow	4	4	-
	45-03-003-001	Hardware (S), Socket Cap Screw, Alloy Steel / Yellow Zinc, M10 x 1.5 x 50mm	4	4	-
	45-05-003-003	Hardware (S), Button Socket Cap Screw, Alloy Steel / Yellow Zinc, M10 x 1.5 x 25mm	4	4	-
	45-12-002-001	Hardware (S), Internal Tooth Lock Washer, Alloy Steel / Zinc, M10	4	4	-
5088 - Hardware Pack - 2.0" Front Bumpstop Spacer					
	23-07-03-001	Mounting Hardware (S), Nut, Fuji / Flanged, M10 x 1.5 / Yellow	2	2	-
	45-04-003-001	Hardware (S), Flat Socket Cap Screw, Alloy Steel / PS11036-S, M10 X 1.5 X 100mm	2	2	-
	600271	JK Rear Lower Spring Retainer Nut Wrench Tool	1	1	-
5095 - Hardware Pack - Rear Sway Bar Link Spacer					
	23-07-02-002	Mounting Hardware (S), Nut, Fuji, M12 x 1.75, Black	2	2	2
	45-02-005-021	Hardware (S), Button Socket Cap Screw, Alloy Steel/ PS11036-S, M12 x 1.75 x 55mm	2	2	2
	55-48-056-048-1-0	Spacer, .480" ID, 0.56" OD, 0.48" Length, 300 Series Stainless Steel, None	2	2	2

NOTES

**RT Suspension Systems include Rear Bumpstops in the JL SpeedBump & Progressive Bump Stop Kit - SKU 1958350

ST/CT/RT Systems include componets for the Rear Track Bar Bracket, parts list can be found in the accompanying instructions 999311.

NOTES

***FOR ALPINE & ALPINE IR CONTROL ARM KITS: Refer to Instruction #999321 before continuing.**

-CONTROL ARMS WITH  BUSHINGS can be torqued with the Jeep raised in the air.

-CONTROL ARMS WITH  BUSHINGS Will need to leave the control arms loose until the end of the installation.

***FOR SPORT CONTROL ARM KITS: Refer to Instruction #999325 before continuing.**

***FOR SPEEDBUMP KITS: Refer to Instruction #999329 before continuing.**

***FOR FRONT TRACK BAR: Refer to Instruction 999340**

***FOR REAR TRACK BAR BRACKET: Refer to Instruction 999311**

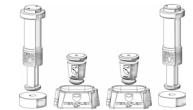
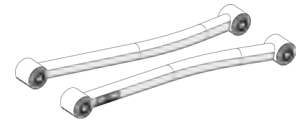

**FRONT INSTALLATION
LIFT AND SUPPORT AT FRAME**

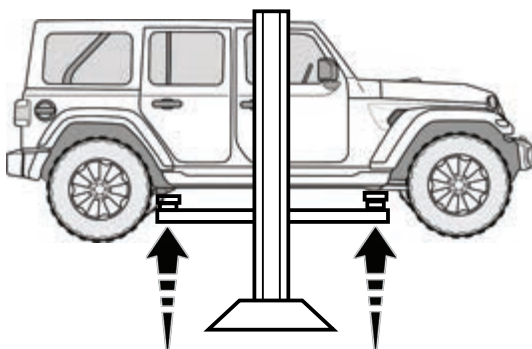
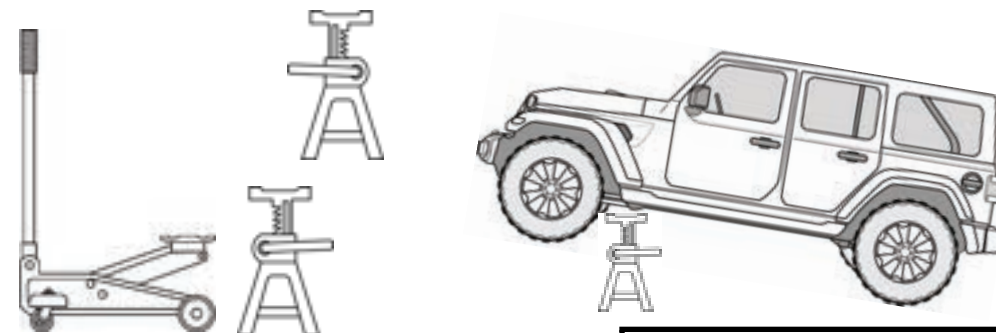

1

REMOVE FRONT TIRES

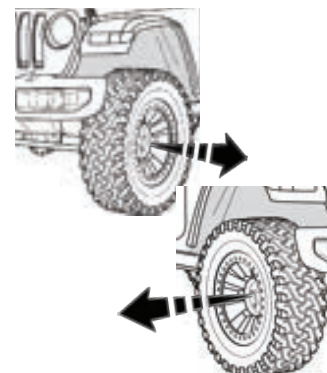

2

SUPPORT FRONT AXLE

3

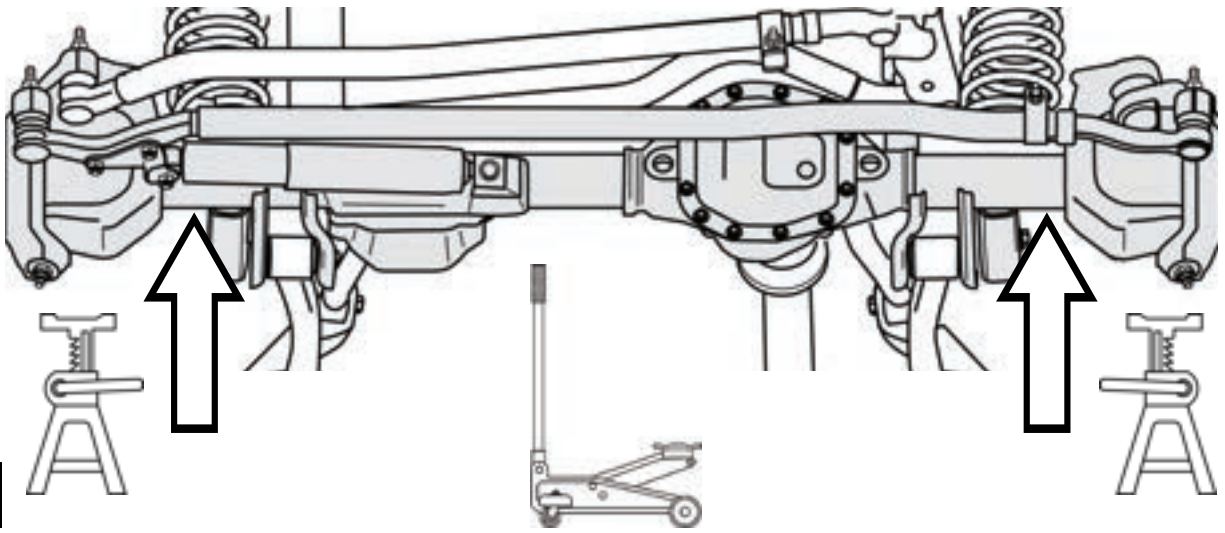

REMOVE SWAY BAR LINKS & REMOVE TRACK BAR BOLT AT AXLE

4

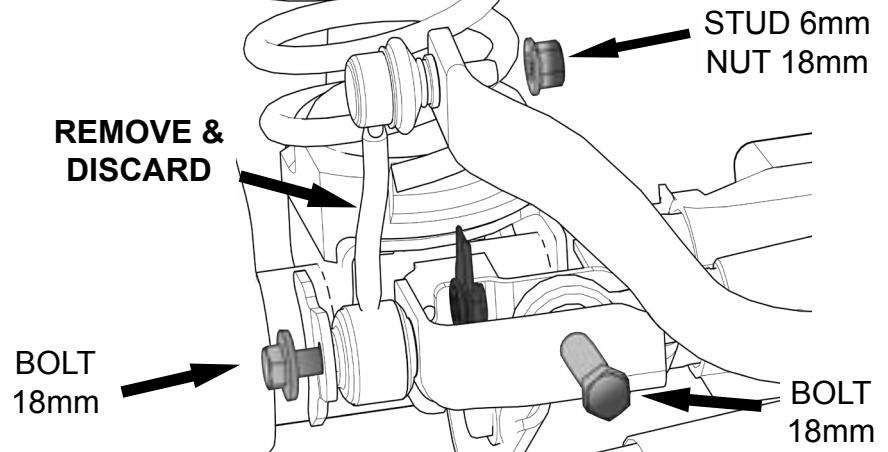

5

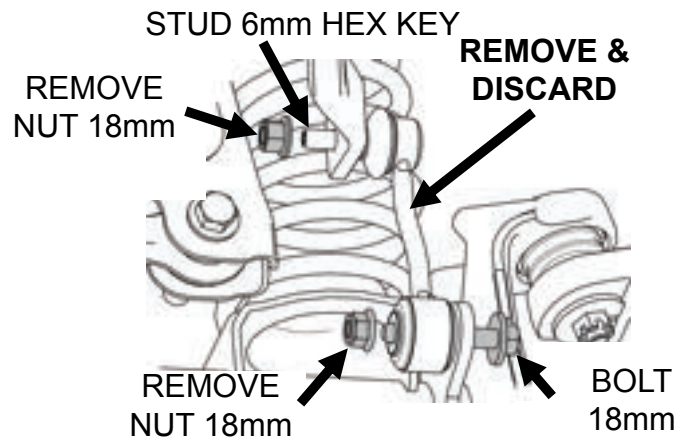
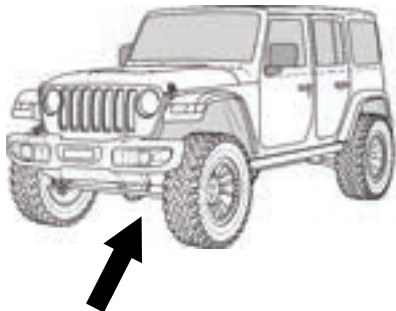

REMOVE AND DISCARD BRAKE LINE BRACKETS FROM LOWER CONTROL ARMS

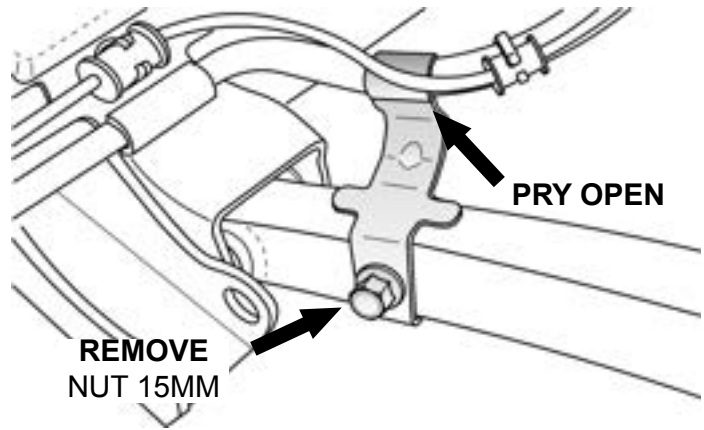
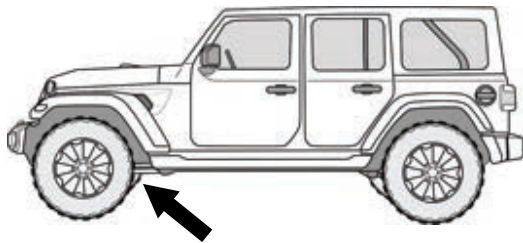
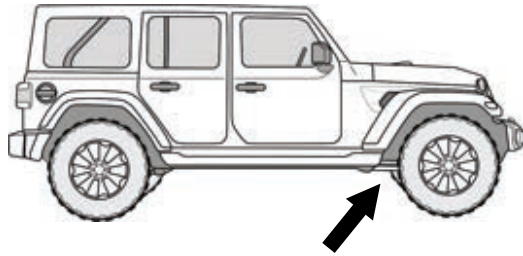

2X
6

DISCONNECT ACTUATORS AND VENT HOSE AT THE FRONT AXLE

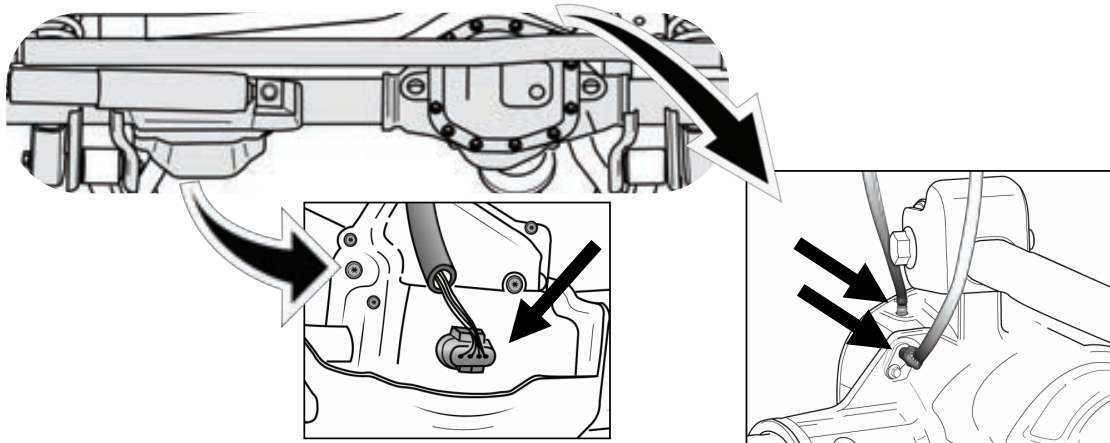

7

**LOOSEN FRONT CONTROL ARM BOLTS
DO NOT REMOVE THE CONTROL ARM BOLTS**

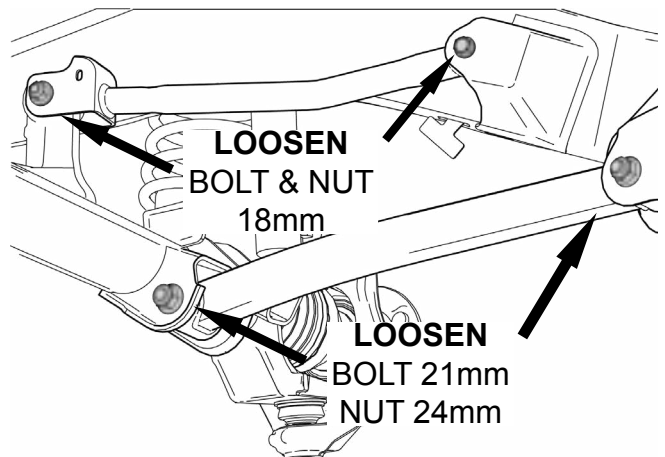
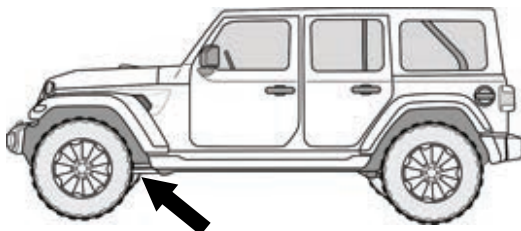
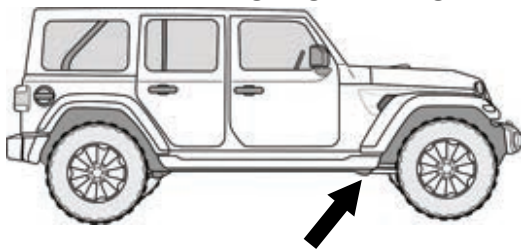

2X
8

REMOVE FRONT SHOCKS

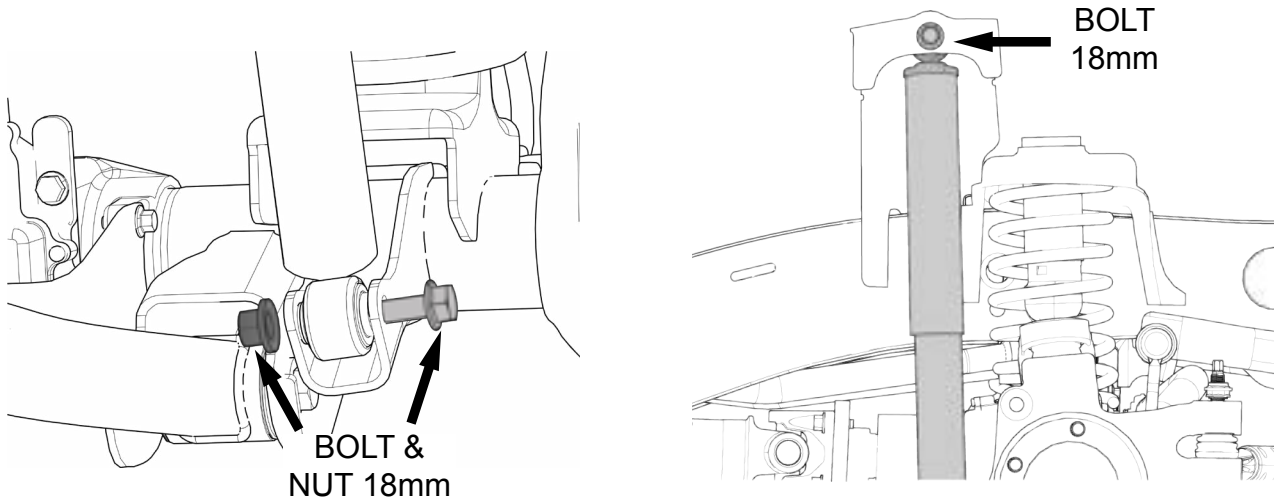

2X
9

LOWER AXLE AND REMOVE FRONT SPRINGS

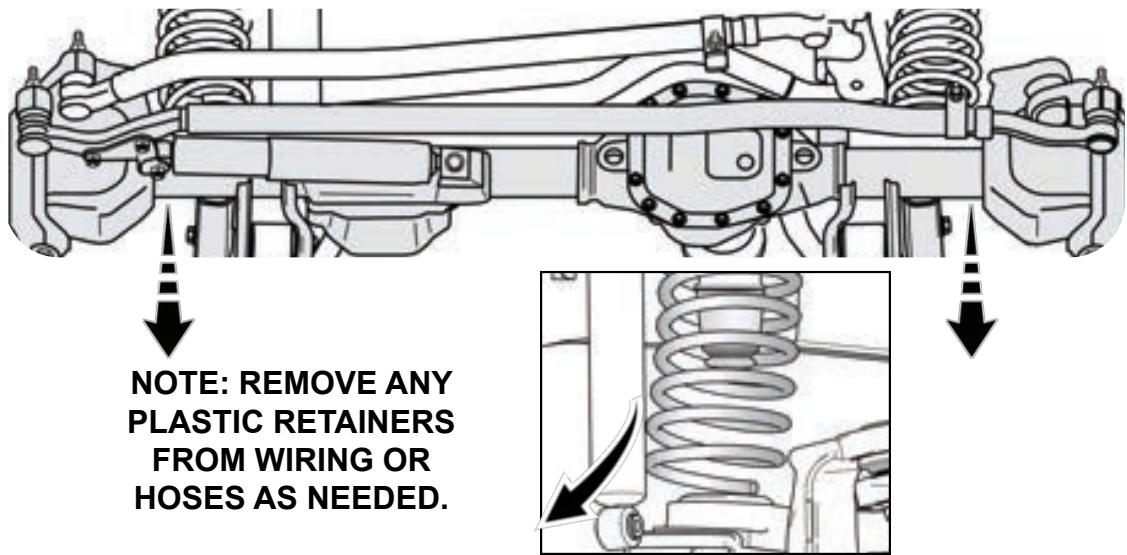

NOTE: REMOVE ANY PLASTIC RETAINERS FROM WIRING OR HOSES AS NEEDED.

2X
10

REFER TO THE SPRING PERCH INSTRUCTIONS #999365

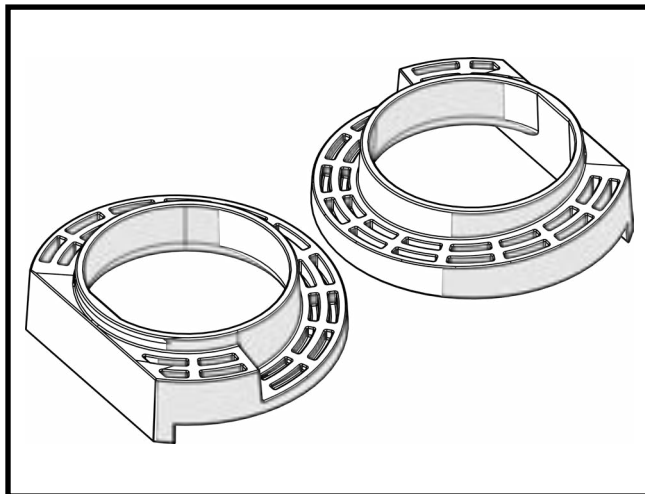

11

INSTALL BUMPSTOP INTO NEW FRONT SPRING

NOTE:

- **FOR FALCON JOUNCE BUMPER KITS:** Refer to instruction #999308
- **FOR SPEEDBUMP KITS:** Refer to Instruction #999329 before continuing.

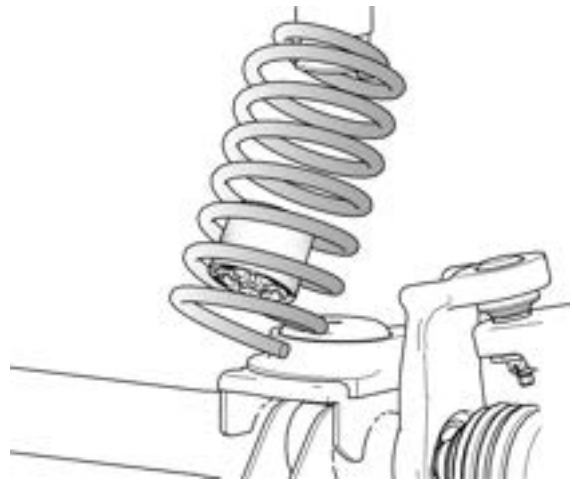
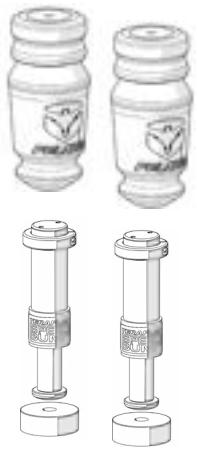

2X

12

NOTE: REFER TO PAGE 17 FOR BUMPSTOP SPACER GUIDE

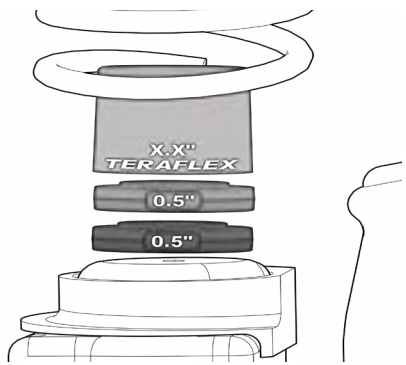

TORQUE 12 FT-LBS

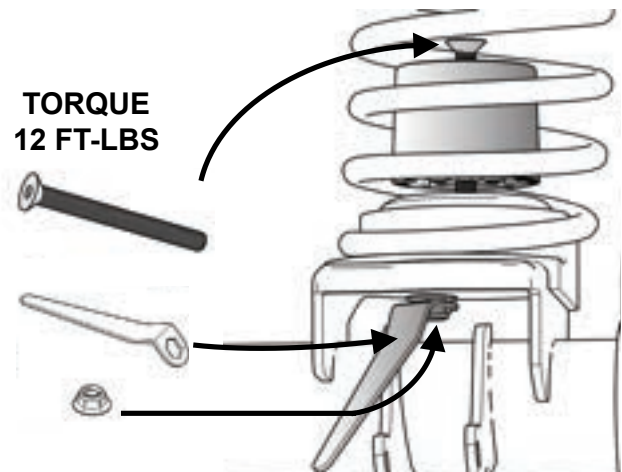

2X

13

FULLY SEAT THE SPRINGS INTO THE LOWER SPRING PERCH

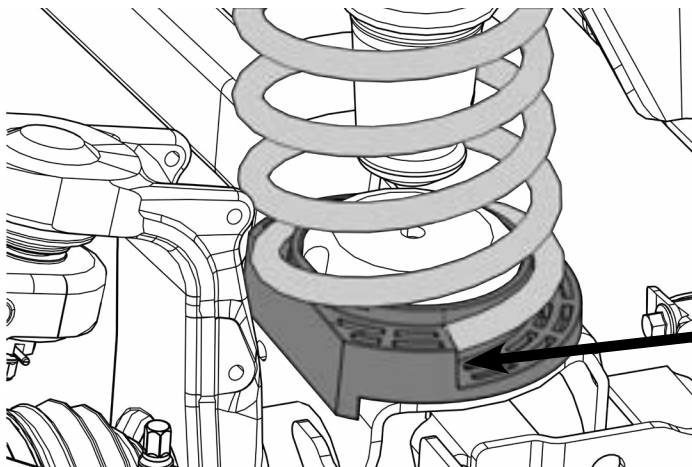

MAKE SURE SPRING IS FULLY SEATED ON PERCH

2X

14

RAISE AXLE & INSTALL SHOCKS

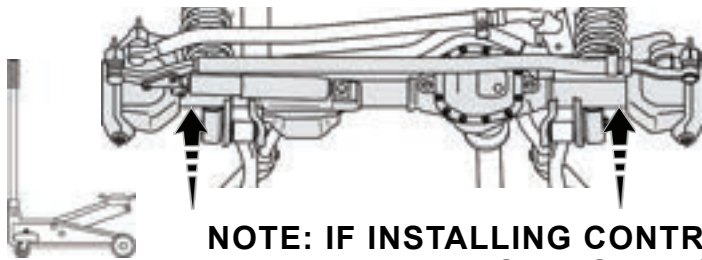

FOR INSTALLING FALCON SHOCKS

(REFER TO QUICK START GUIDE INSIDE FALCON SHOCK BOX)



NOTE: IF INSTALLING CONTROL ARMS WITH ALPINE BUSHINGS, AND THE JEEP WAS RAISED FOR INSTALLATION, LOWER THE JEEP TO THE GROUND AND FINISH INSTALLATION BY TORQUING THE CONTROL ARM BOLTS.

NOTE: IF INSTALLING CONTROL ARMS WITH ALPINE IR BUSHINGS THE CONTROL ARMS CAN BE TORQUED WITH THE JEEP RAISED IN THE AIR. REFER TO PAGE 16 FOR TORQUE SETTINGS

15

RECONNECT CONNECTIONS TO FRONT AXLE

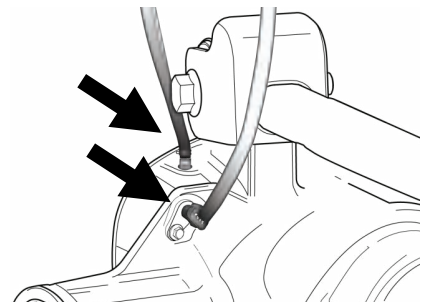
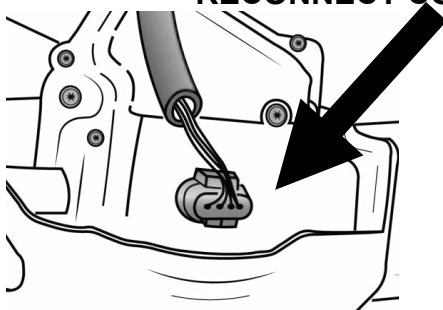

RECONNECT PLASTIC RETAINERS FROM WIRING OR HOSES AS NEEDED.

NOTE: IT IS EASIEST TO RE-INSTALL TRACK BAR AFTER JEEP IS BACK ON THE GROUND

16

INSTALL BRAKE LINE ANCHORS

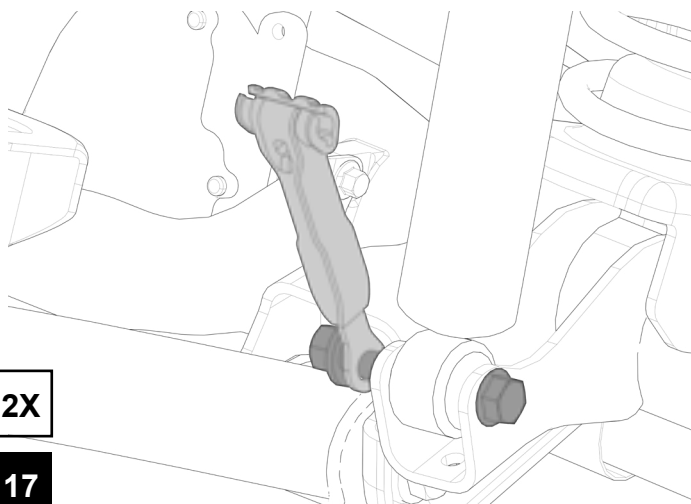

REFER TO THE INSTRUCTIONS ON THE BACK OF THE BRAKE LINE ANCHOR KIT BOX FOR PROPER INSTALLATION.

2X

17

INSTALL FRONT SWAY BAR LINKS

**INSTALL ON
2024+ JL ONLY**
2018-23 JL
spacer is not needed

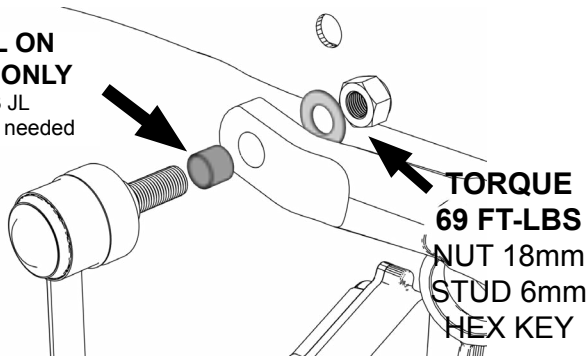

**TORQUE
59 FT-LBS
BOLT 18mm**

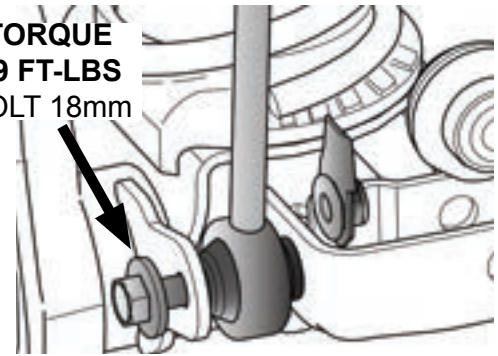

**NOTE: IF INSTALLING QUICK
DISCONNECTS, REFER TO
INSTRUCTIONS #999372**

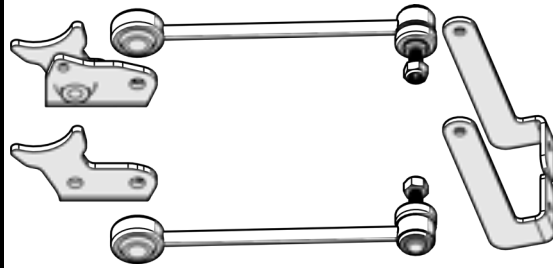

18

**NOTE: IF ONLY FRONT OF JEEP WAS LIFTED, REINSTALL TIRES AND LOWER JEEP
BACK TO THE GROUND BEFORE LIFTING THE REAR**

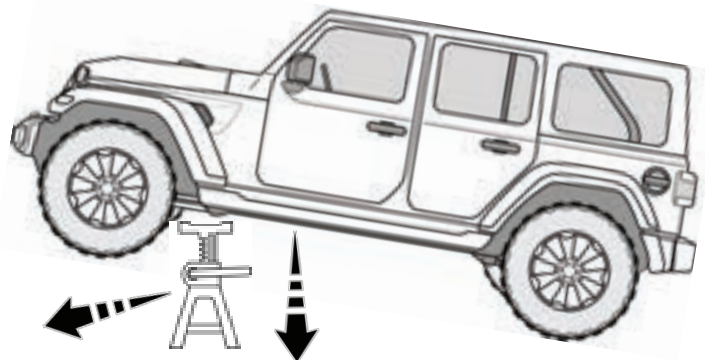
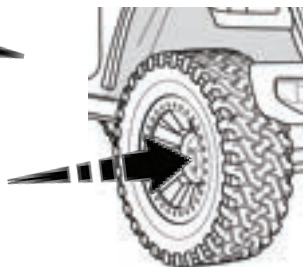

19

TORQUE THE FRONT TIRES TO 130 FT LBS

REAR INSTALL LIFT AND SUPPORT AT FRAME

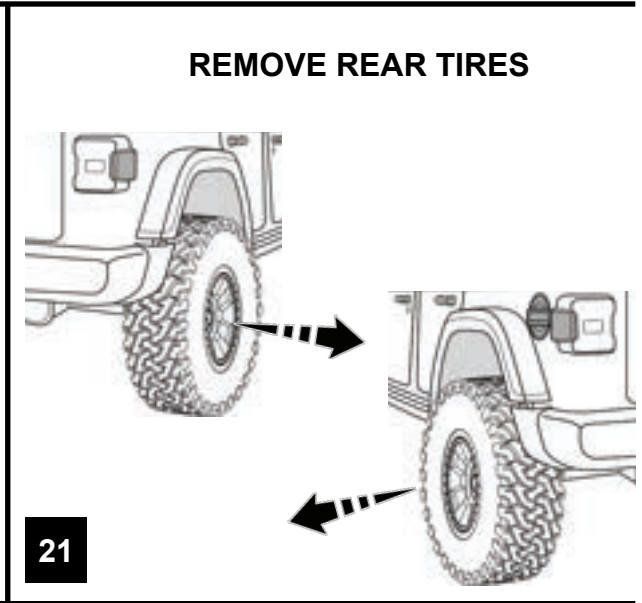
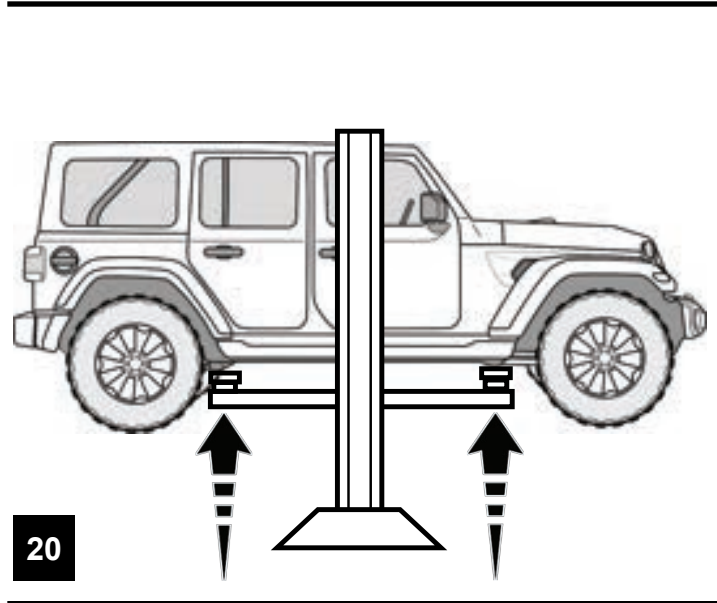
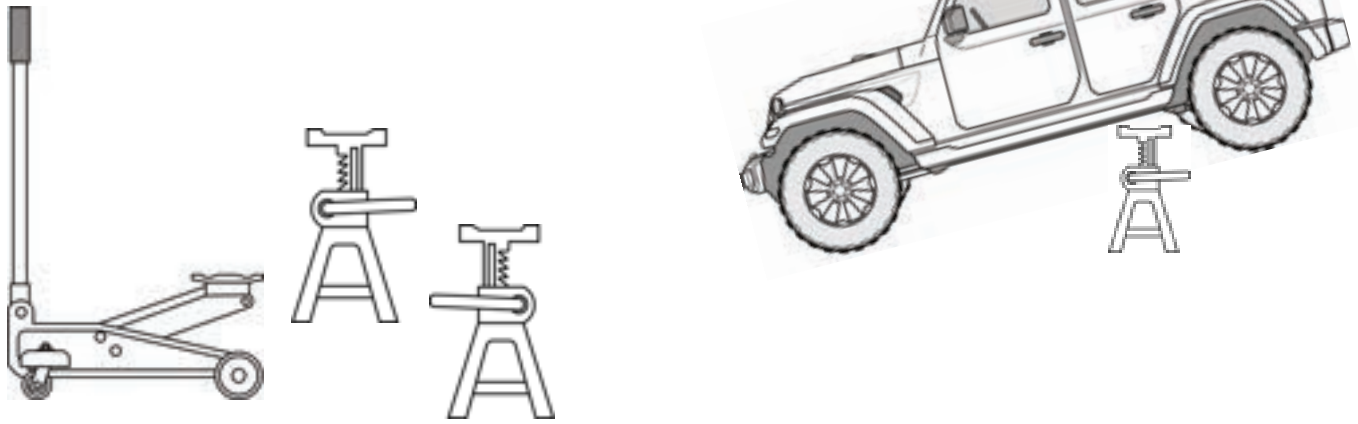

SUPPORT REAR AXLE

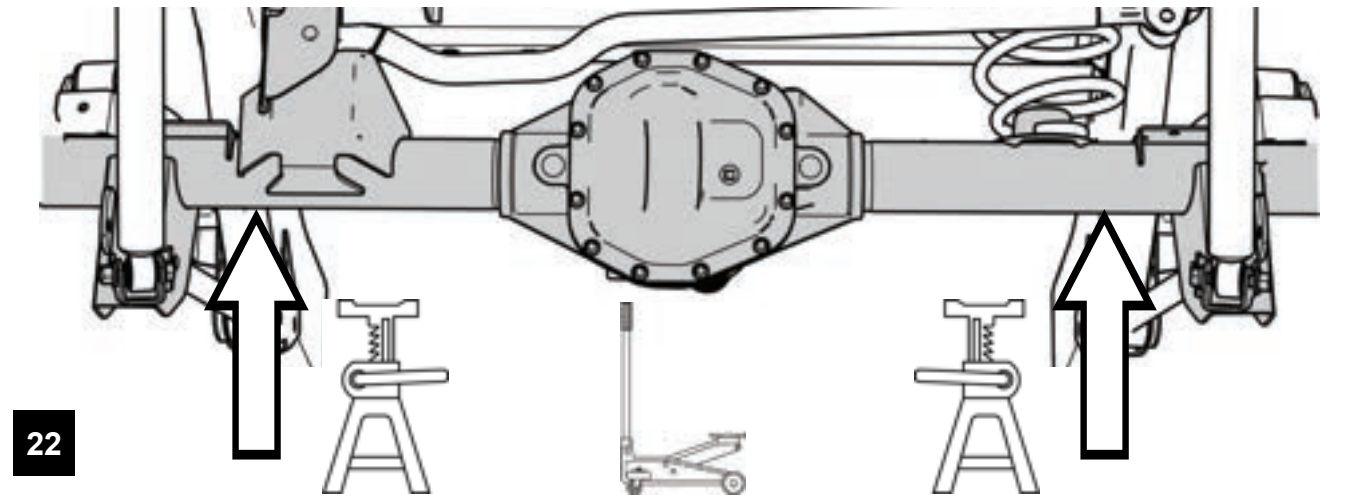

REMOVE E-BRAKE CABLE BRACKET AND DISCARD

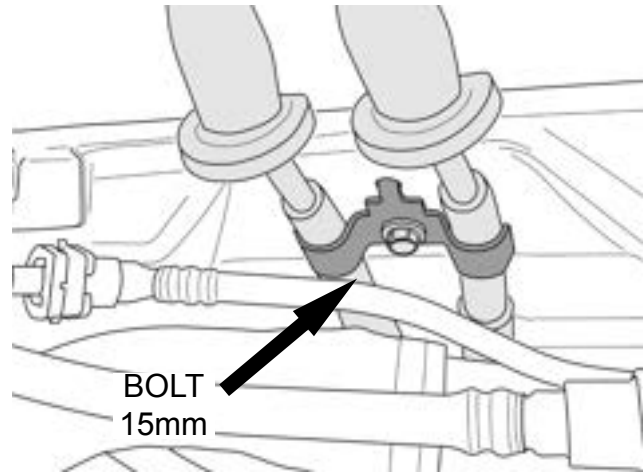
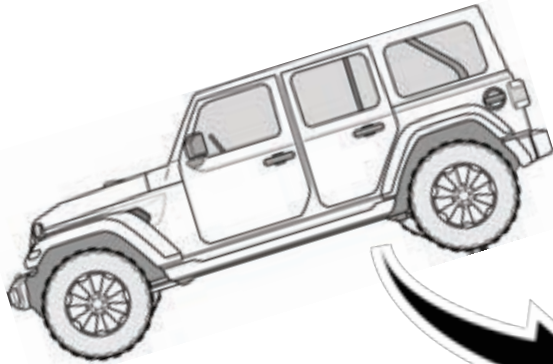

BOLT
15mm

23

SET THE E-BRAKE AND CLAMP BOTH E-BRAKE EYELETS AGAINST BACKING PLATES WITH LOCKING PLIERS

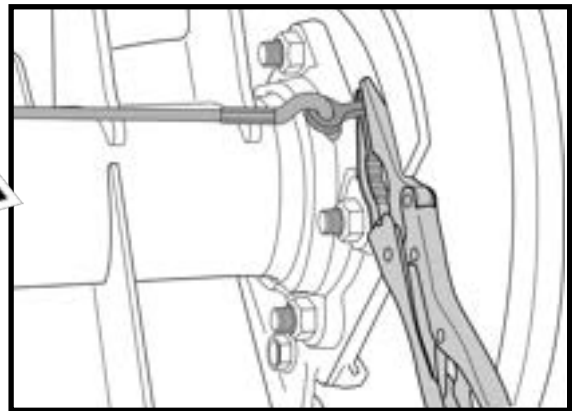
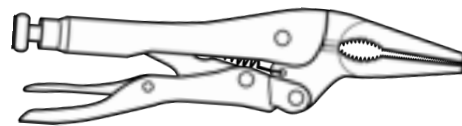
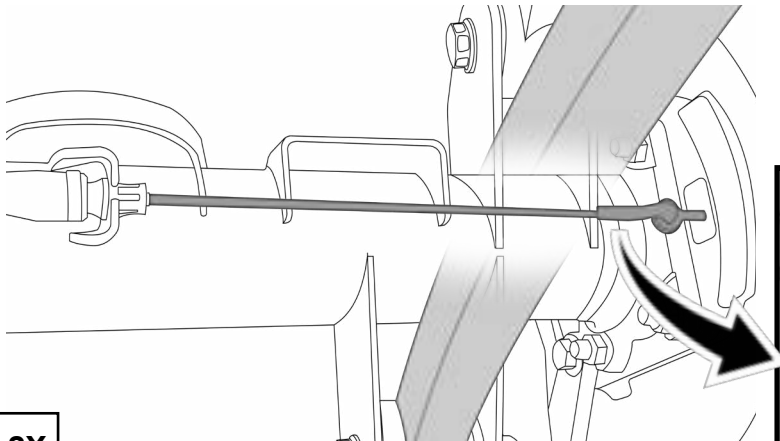

2X

24

RELEASE E-BRAKE AND DISCONNECT CABLES FROM BOTH EYELETS AND AXLE BRACKETS

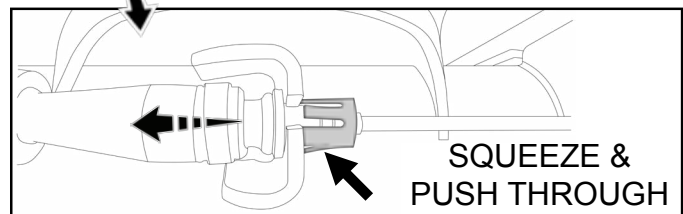
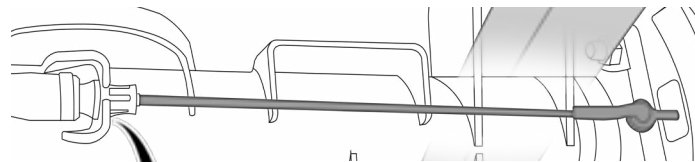
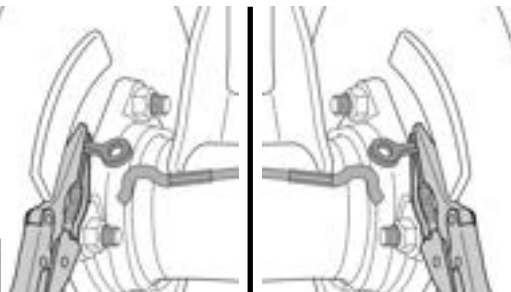

SQUEEZE &
PUSH THROUGH

2X

25

NOTE: DO NOT REMOVE LOCKING PLIERS FROM E-BRAKE EYELETS

ROUTE E-BRAKE CABLES UNDER CROSS MEMBER AND FUEL LINES.

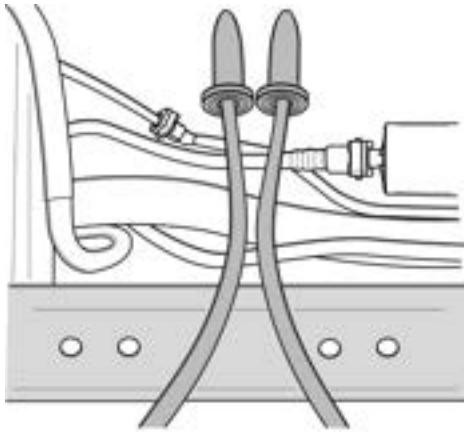

26

RECONNECT E-BRAKE CABLES TO THE AXLE BRACKETS AND THEN THE E-BRAKE EYELETS.

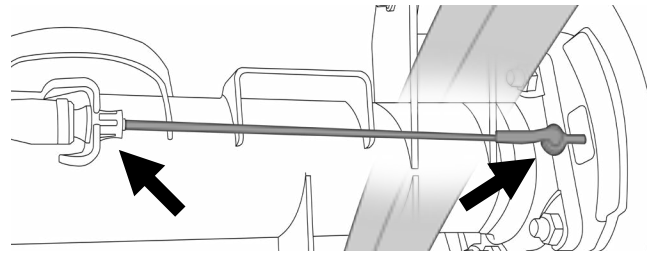

2X

27

REMOVE PLIERS FROM E-BRAKE EYELETS

LOOSEN REAR CONTROL ARM BOLTS

DO NOT REMOVE THE CONTROL ARM BOLTS

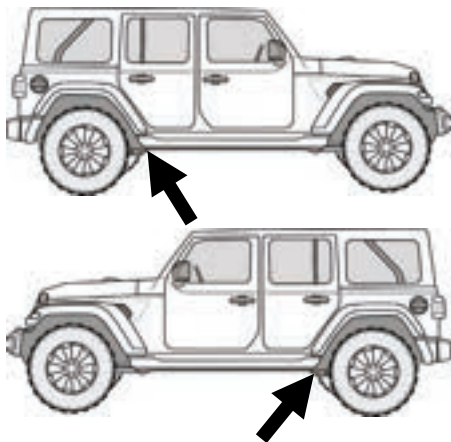

2X

28

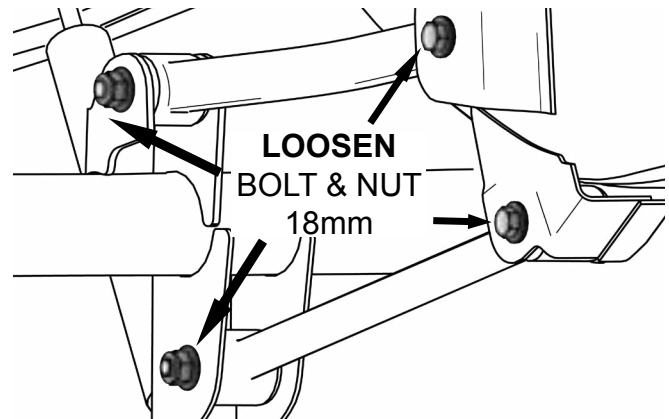

REMOVE AND DISCARD SWAY BAR LINKS

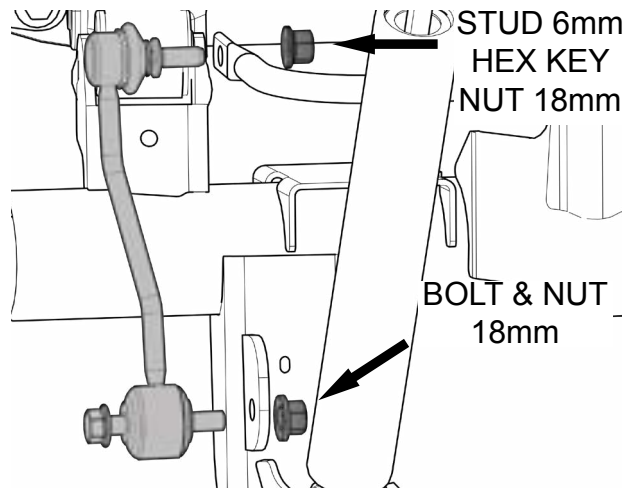

2X

29

REMOVE BRAKE LINE BRACKETS FROM BOTH SIDES OF THE AXLE

2X
30

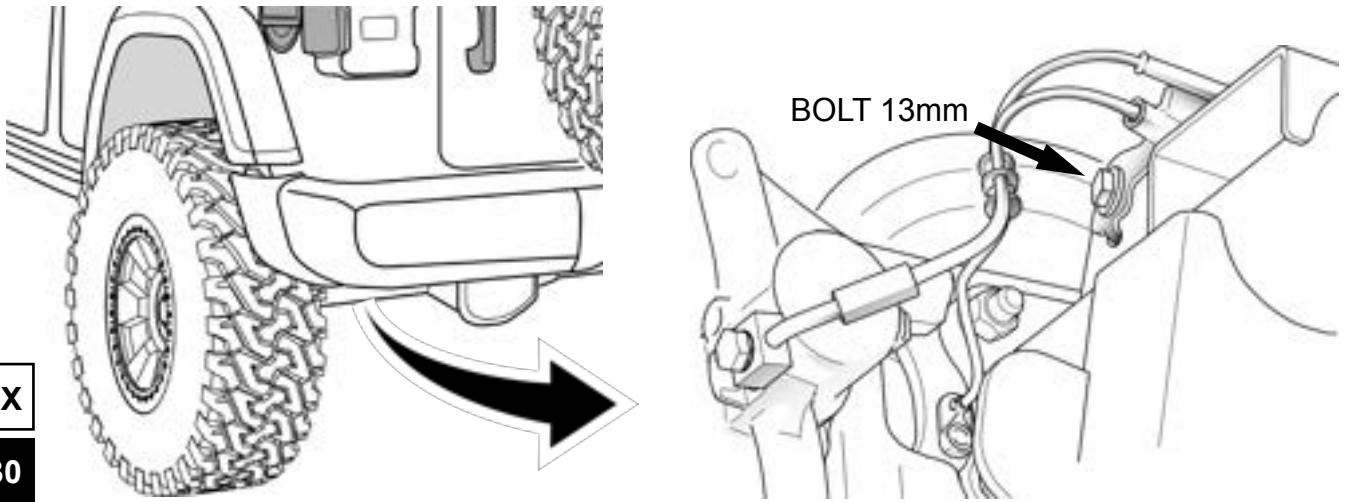

REMOVE THE TRACK BAR FROM THE AXLE

31

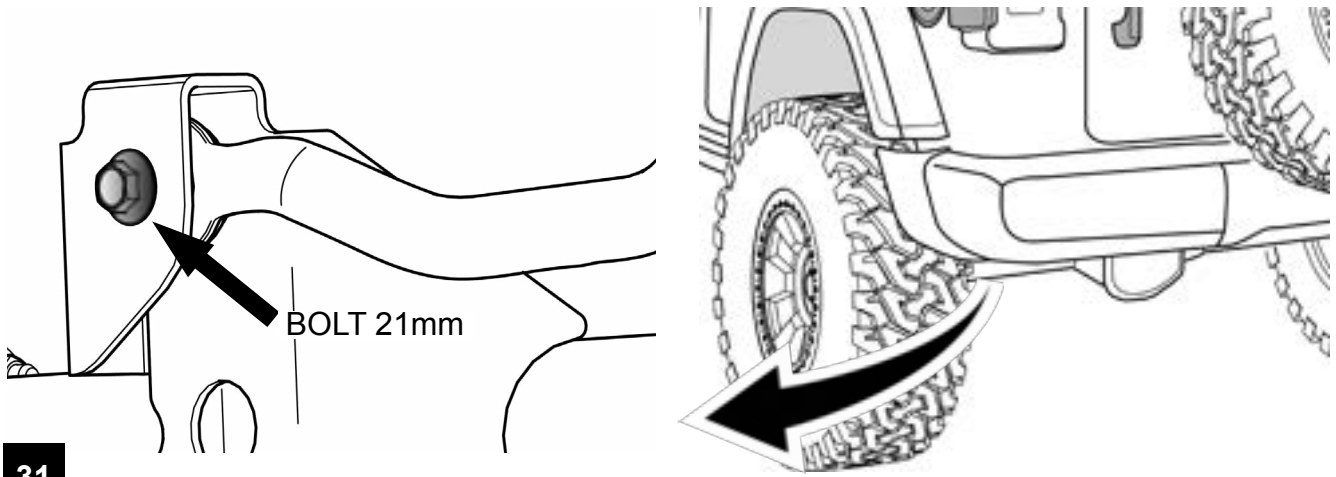

REMOVE THE REAR SHOCKS

2X
32

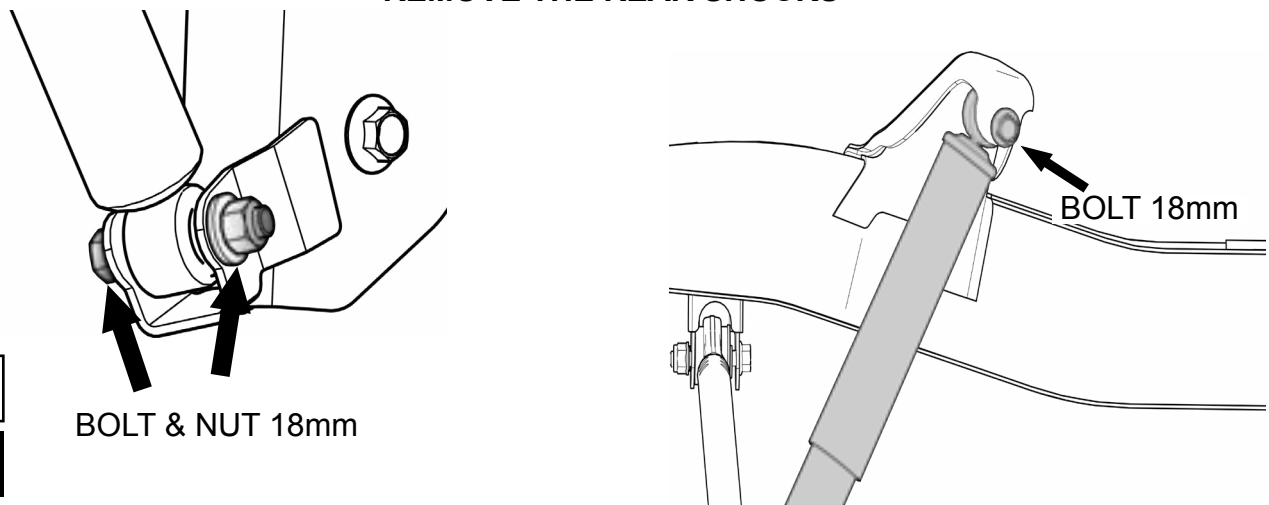

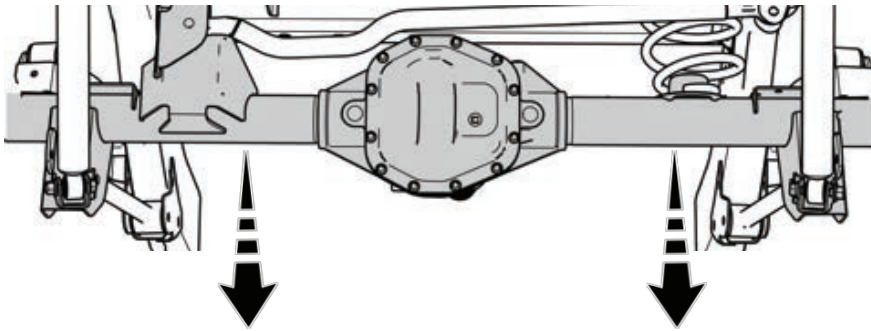
LOWER AXLE TO REMOVE & DISCARD REAR SPRINGS**2X****33**

NOTE: REMOVE ANY PLASTIC RETAINERS FROM WIRING OR HOSES AS NEEDED.

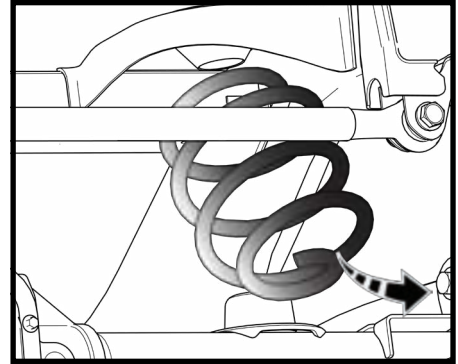
**INSTALL NEW REAR SPRINGS**

NOTE: 3.6L V6, 2.0L I4, DIESEL & 392 VEHICLES HAVE SIDE SPECIFIC REAR SPRINGS. ON 4xe VEHICLES THE SIDE SPECIFIC SPRING ARE NOT NECESSARY FOR THIS LIFT HEIGHT. SEE THE PARTS LIST TO DOUBLE CHECK YOUR SPRINGS.

INSTALL THE DRIVERS SIDE SPRING**LEFT REAR SPRINGS**

3.6L V6 & 2.0L I4 4 DOOR: 02-22-211-250-1

3.6L V6 & 2.0L I4 2 DOOR: 02-22-211-200-1

4xe 4 DOOR: 02-22-431-350-1

DIESEL 4 DOOR: 02-22-411-250-1

392 4 DOOR: 02-22-411-400-1

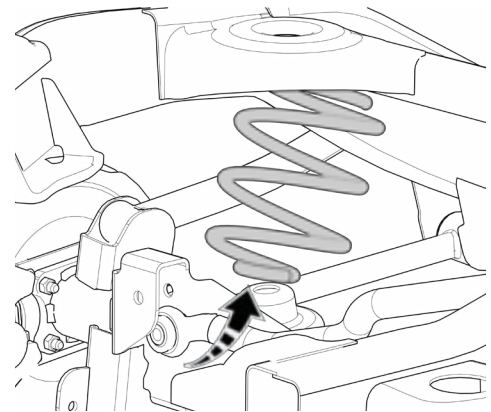
34**INSTALL THE PASSENGERS SIDE SPRING****RIGHT REAR SPRINGS**

3.6L V6 & 2.0L I4 4 DOOR: 02-22-221-250-1

3.6L V6 & 2.0L I4 2 DOOR: 02-22-221-200-1

4xe 4 DOOR: 02-22-431-350-1

DIESEL 4 DOOR: 02-22-421-250-1

392 4 DOOR: 02-22-421-400-1

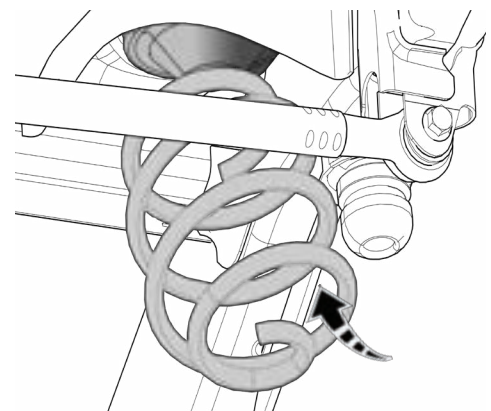
35

RAISE THE REAR AXLE AND INSTALL SHOCKS

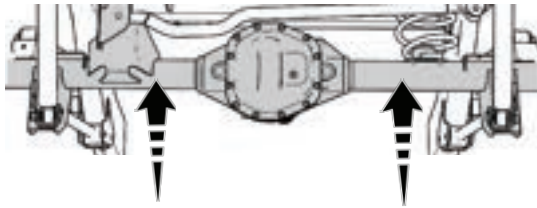

MAKE SURE TO FULLY SEAT THE SPRINGS INTO THE UPPER SPRING ISOLATOR

INSTALLING FALCON SHOCKS
(REFER TO QUICK START GUIDE INSIDE FALCON SHOCK BOX)

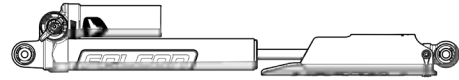

NOTE: IF INSTALLING CONTROL ARMS WITH ALPINE BUSHINGS, AND THE JEEP WAS RAISED FOR INSTALLATION, LOWER THE JEEP TO THE GROUND AND FINISH INSTALLATION BY TORQUING THE CONTROL ARM BOLTS.

IF INSTALLING CONTROL ARMS WITH ALPINE IR BUSHINGS THE CONTROL ARMS CAN BE TORQUED WITH THE JEEP RAISED IN THE AIR. REFER TO PAGE 16 FOR TORQUE SETTINGS

36

**TORQUE
25 FT-LBS
BOLT 6mm HEX
NUT 14mm**

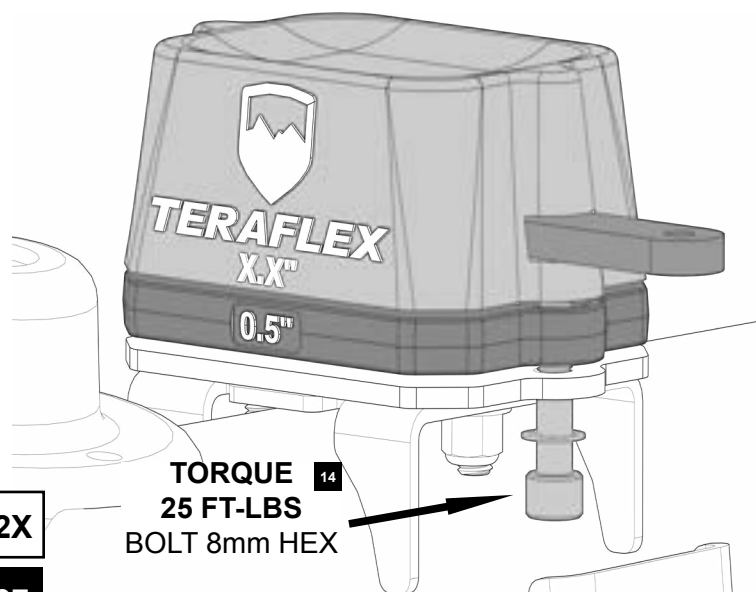
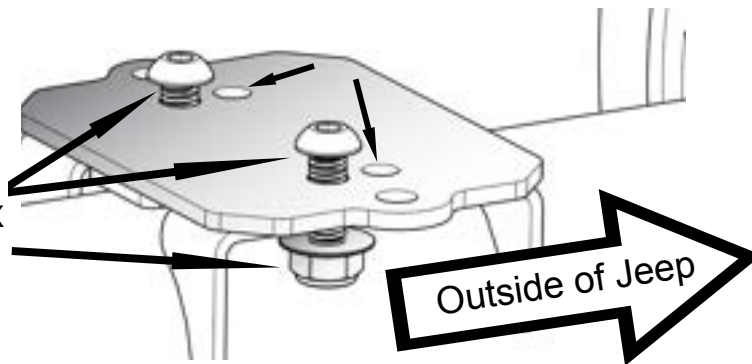

**TORQUE ¹⁴
25 FT-LBS
BOLT 8mm HEX**

2X

37

NOTE: REFER TO PAGE 17 FOR BUMPSTOP SPACER GUIDE

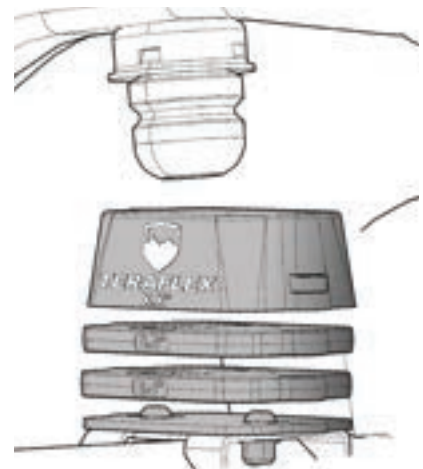

REINSTALL BRAKE LINE BRACKETS

RECONNECT PLASTIC RETAINERS FROM WIRING OR HOSES AS NEEDED

REINSTALL BOLT 13mm

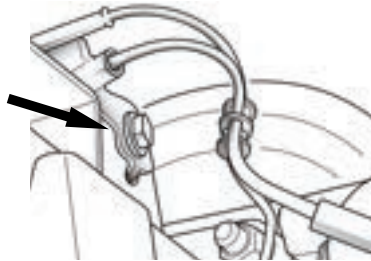

2X

NOTE: DO NOT TIGHTEN THE CONTROL ARM BOLTS UNTIL THE JEEP IS ON THE GROUND

38

INSTALL NEW SWAY BAR LINKS

TORQUE 45 FT-LBS
NUT 19 mm
BOLT 8mm
HEX KEY

TORQUE 66 FT-LBS
NUT 19mm
STUD 6mm
HEX KEY

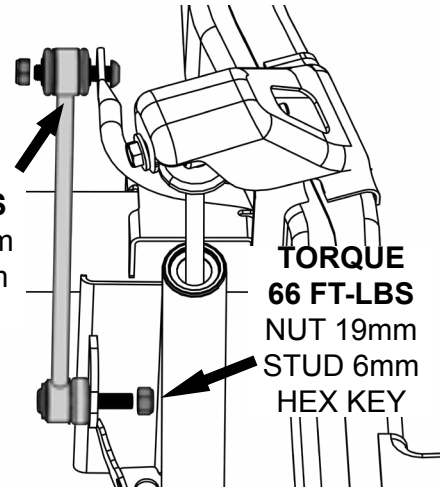

2X

39

REINSTALL TIRES AND LOWER TO THE GROUND

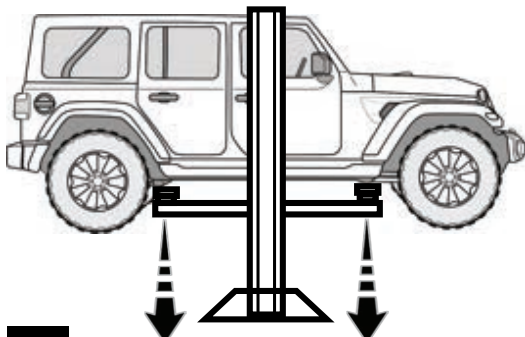

40

TORQUE TO 130 FT LBS

REINSTALL TRACK BARS AND TORQUE TO THE FOLLOWING SPECS

TORQUE REAR
BOLT 21mm
74 Ft Lbs + 60°

41

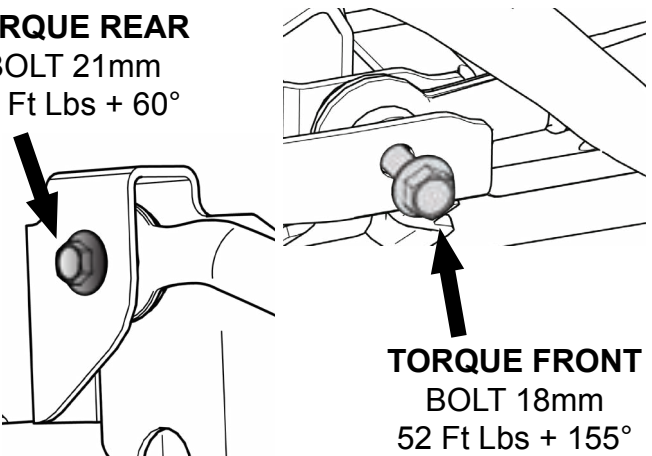

TORQUE FRONT
BOLT 18mm
52 Ft Lbs + 155°

TORQUE CONTROL ARMS

REAR

TORQUE 21mm
74Ft Lbs + 65°
(REF: 123 Ft Lbs)

TORQUE 21mm
74Ft Lbs + 80°
(REF: 169 Ft Lbs)

TORQUE 21mm
74Ft Lbs + 50°
(REF: 121 Ft Lbs)

TORQUE 21mm
74Ft Lbs + 50°
(REF: 150 Ft Lbs)

2X

42

FRONT

TORQUE 18mm
41 Ft Lbs + 185°
(REF: 140-160 Ft Lbs)

TORQUE 18mm
37 Ft Lbs + 135°
(REF: 100-120 Ft Lbs)

TORQUE
103 Ft Lbs +145°
(REF: 230-250 Ft Lbs)
BOLT 21mm
NUT 24mm

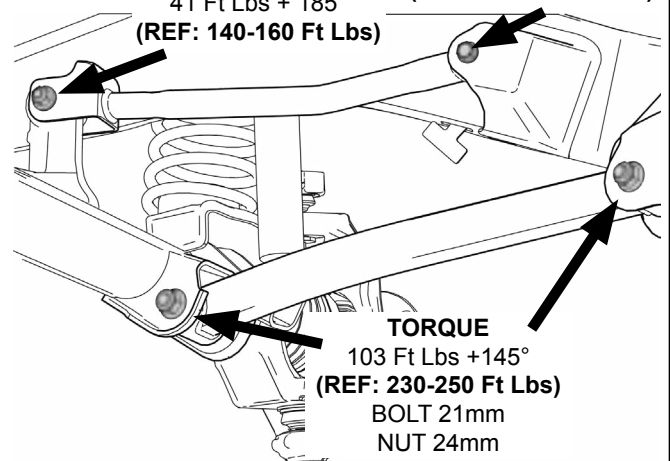

JL TIRE CLEARANCE GUIDE for vehicles with FACTORY FENDER FLARES

TeraFlex Bump Stop Strike Pad Extensions allow the use of larger tires and factory fender flares by limiting suspension up travel.

JL Rubicon models feature high-clearance fenders that allow for more up travel, while the lower-clearance fenders on JL Sport and Sahara restricts tire size due to fender rubbing.

In order to address these fender differences, TeraFlex designed a proprietary modular bump stop system, which can be adapted to fit several different tire size configurations.

JL RUBICON

with Factory Fender Flares:

33" TIRES

- No Front or Rear Bump Stops

Compatible Lift Kit Heights: 1.5"

35" TIRES

- 2" Front & 2" Rear Bump Stops

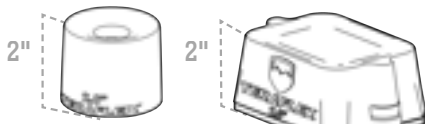

Compatible Lift Kit Heights: 2.5"-4.5"

37" TIRES

- 2.5" Front & 3" Rear Bumps

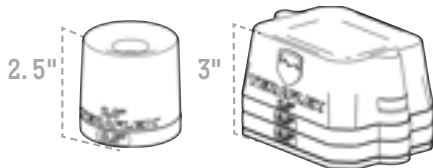

Compatible Lift Kit Heights: 2.5"-4.5"

Notes:

- If installing on an Eco-Diesel or 392 Wrangler, the factory jounce tubes are longer. Subtract the following amount from the front bumpstop stack as stated above:

- **Eco-Diesel - Subtract 1.375" from the front bump stop stack.**
- **392 Wrangler - Subtract 1.875" from the front bump stop stack.**

- If a 1.5" Performance Spacer lift kit is installed and a little bit of bump stop is needed, Front and Rear Bump Stop Strike Pads are available for individual purchase.

- If installing 39"+ tires, it is recommended that you replace the factory fender flares.

- If 3.5"-4.5" Lift Falcon Shocks are installed, then a minimum of 2" bump stop is needed.



801.713.3314 • TERAFLEX.com

Rev C 999320

Additional 0.5" shims can be added to fine tune bump stop height and further limit suspension up travel.

IMPORTANT: Recommended Bump Stop configuration is based on tested tires. Not all tires measure the same. Before driving, cycle the suspension to check for rubbing or contact of the shocks, springs, or suspension componets.

JL SPORT/SAHARA

with Factory Fender Flares:

33" TIRES

- No Front or Rear Bump Stops

Compatible Lift Kit Heights: 1.5"

35" TIRES

- 3" Front & 2.5" Rear Bump Stops

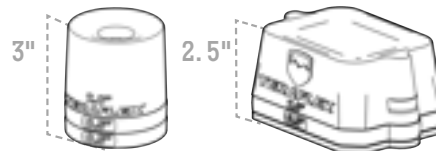

Compatible Lift Kit Heights: 2.5"-4.5"

37" TIRES

- 3.5" Front & 4" Rear Bump Stops

**Additional Bump Stops Required

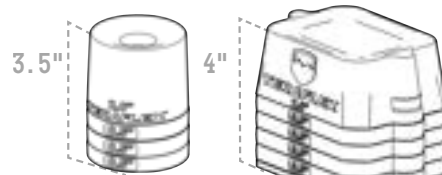

Compatible Lift Kit Heights: 4.5"

2-4 Inch Shock Options

JL Falcon Adjustable PiggyBack Shocks

- 4 Door Series 3.3, 11-01-33-400-200-3
- 2 Door Series 3.3, 10-01-33-400-200-3

- *Fast Adjust Knob
- *High Flow Oil Channel
- *Offset Sleeve Design
- *PiggyBack Reservoir

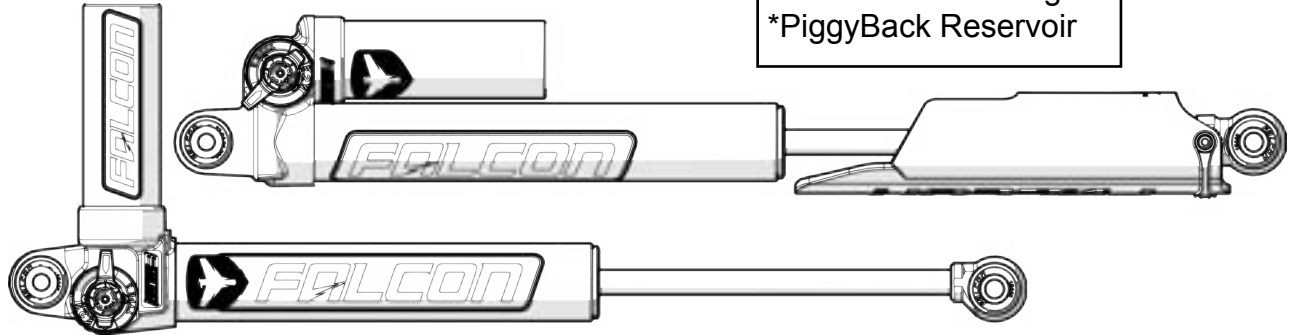

JL Falcon PiggyBack Shocks

- 4 Door Series 3.1, 11-01-31-400-200-3
- 2 Door Series 3.1, 10-01-31-400-200-3

- *Series 3.3 Upgradable
- *High Flow Oil Channel
- *Offset Sleeve Design
- *PiggyBack Reservoir

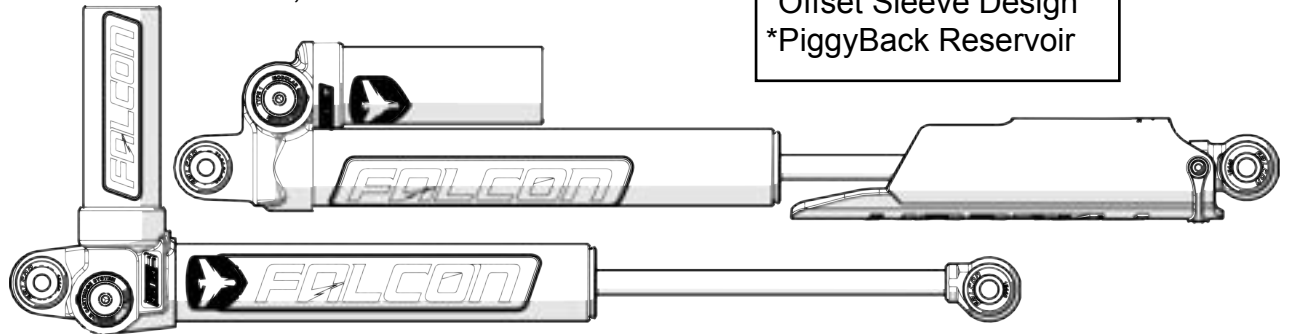

JL Falcon Monotube Shocks

- 4 Door Series 2.1, 11-01-21-400-200-3
- 2 Door Series 2.1, 10-01-21-400-200-3

- *Oil Gas Separator
- *3/4" Chrome Shaft
- *Offset Sleeve Design
- *JL Specific Shock

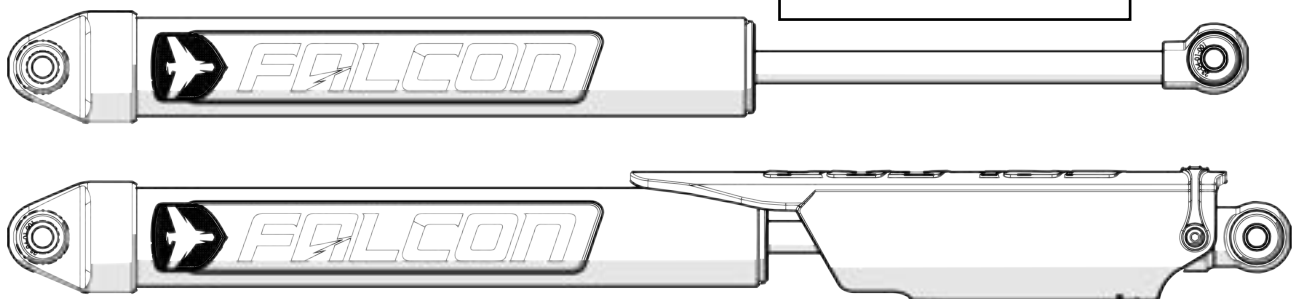

TERAFLEX

PRODUCT INFORMATION

MAINTENANCE INFORMATION:

It is the buyer's responsibility to have all suspension, drivetrain, steering, and other components checked for proper tightness and torque after the first 100 miles and every 3000 miles after that.

NOTICE TO INSTALLER:

The enclosed "Warning to Driver" sticker must be installed in the vehicle in driver's view. This sticker is to act as a constant safety reminder when operating the vehicle. It is your responsibility as the equipment installer to install the provided sticker and to forward the product instructions to the vehicle's owner for review. If a "Warning to Driver" sticker or product installation guide were not included in the kit, FREE replacement stickers and instructions are available by request. It is the installer's duty to ensure a safe and controllable vehicle after the modifications have been performed.

WARNING:

Neither the seller nor the manufacturer will be liable for any loss, damage, or injury directly or indirectly arising from the use of or inability to determine the use of these products. Before using, the user shall determine the suitability of the products for its intended use, and the user shall assume all responsibility and risk in connection therewith.

WARNING TO DRIVER:

This vehicle has been modified to enhance off road performance and has unique handling characteristics. Use in harsh environments can cause extreme stress on the components. Vehicle should be inspected after being off road to make sure that all the components are in working order and safe to travel on the highway. All fasteners should be checked so that they are at the correct torque specifications as the vibration and stresses from off roading may cause critical fasteners to work loose. Extra care should be taken to inspect the critical components, steering, and brake systems. During each oil change components such as arms, tie rod ends, etc should be greased and checked for excessive wear. Any worn components should be replaced. When returning to the pavement always set or restore tire air pressure to the factory recommendation and connect or engage any disabled sway bar mechanisms. Because of the higher center of gravity and larger tires, this vehicle handles and reacts differently than many passenger cars, both on and off road. You must drive it safely! Extreme care should be taken to prevent vehicle rollover or loss of control, which can result in serious injury or death. Avoid sudden sharp turns or abrupt maneuvers. Generally, braking performance and capabilities are decreased when significantly larger/heavier tires are used, especially when used in combination with transfer case low-range reduction kits. Take this into consideration while driving. Do not add, alter or fabricate any factory or aftermarket parts to increase vehicle height over the intended height of the TeraFlex product purchased. Mixing component brand is not recommended. TeraFlex Inc. will not be responsible for any altered product or any improper installation or use of our products. We will be happy to answer any questions concerning the design, function, and correct use of our products. It is ultimately the buyer's responsibility to have all bolts/nuts checked for tightness after the first 100 miles and then every 3000 miles. Wheel alignment, steering system, suspension and drive line systems must be inspected by a qualified professional mechanic at least every 3000 miles.

TERAFLEX PRODUCT WARRANTY:

TeraFlex Inc. warrants TeraFlex Suspension products to the original retail purchaser to be free of defects in material and workmanship for as long as the original purchaser owns the vehicle on which products were originally installed.

Failure to complete regular maintenance (grease every 3000 miles) on TeraFlex FlexArms will void this warranty. All other conditions of the standard TeraFlex product warranty apply.

All TeraLow products are covered by the TeraFlex two (2) year warranty to be free of defects in material and workmanship for two years from date purchased.

TeraFlex axles are covered by a 12-month warranty to be free of defects in materials and workmanship.

This warranty does not cover or include product finish, improperly installed or applied products, improperly maintained products, products or components used for racing or competition or damage due to abuse or neglect, products that fail due to the use of larger tire and wheel combinations.

All returns must be accompanied by an original invoice. It is the customer's responsibility to remove the product from the vehicle. Shipping charges are the responsibility of the customer. TeraFlex Inc. will pay the return freight if the product meets the terms of warranty.

This warranty is for the replacement or repair of defective TeraFlex products only and does not include freight charges, labor charges for removal of or installation of TeraFlex or related products or components, costs incurred due to down time of the vehicle, or lost profits due to vehicle down time.

A returned goods authorization number (RGA#) must accompany any returned products. For more information please contact a TeraFlex customer service representative.

COPYRIGHT

©Copyright 2014. All rights reserved, TeraFlex Inc. Reproduction of this catalog and/or any of its contents without written permission is strictly prohibited.

TeraFlex® is a registered trademark of TeraFlex Inc. All trade names and logos including but not limited to TeraFlex, FlexArms, RockGuard, Monster, and LCG are protected by law and duplication of trade names and/or logos are strictly prohibited.

TeraFlex Inc. reserves the right to update, discontinue, redesign, modify finish, part number or component build parts if deemed necessary without written notice. TeraFlex Inc., and any associated dealers are not responsible for misprints or typographical errors that may have inadvertently been made within this instruction sheet.

Jeep® and the Jeep® grill are registered trademarks of Fiat Chrysler Automobiles N.V., and have no affiliation with TeraFlex Inc.

TERAFLEX, Inc.
5680 West Dannon Way
West Jordan, UT. 84081
Phone/801.713.3314
Fax/801.713.2313
www.teraflex.com